



*MODEL FRA
FRAMED RETAINING ANGLES FOR
U.L. FIRE DAMPER INSTALLATIONS*

Standard Construction:

16 ga. 1-1/2" x 1-1/2" (38 mm x 38 mm)
Formed Galvanized Steel with staked corners.

Sizes: Maximum and minimum sizes correspond to the individual damper model. Check the appropriate submittal sheet or size chart.

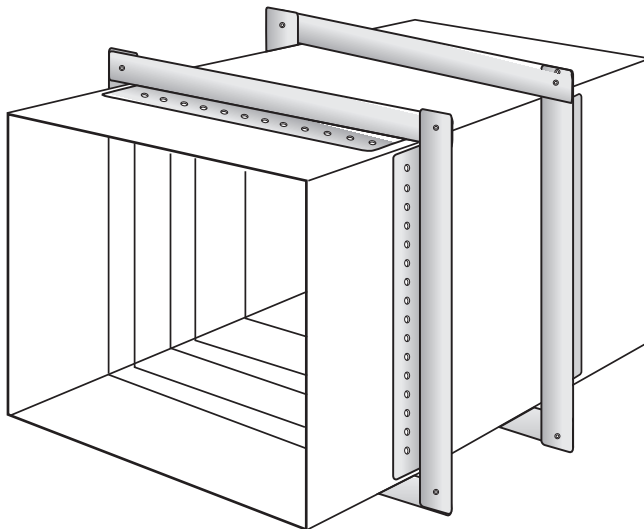

Application:

NCA Model FRA Framed Retaining Angles may be used instead of the normal mounting angles being used at present. The model FRA retaining angles can be installed on NCA curtain fire dampers, multi-bladed fire dampers and combination fire/smoke dampers with 1-1/2 hr. or 3 hr. vertical or horizontal fire ratings. FRA angles are factory supplied two per damper.

Manufacturer's Recommendations

All moving parts of the damper must be inspected and cycled at intervals not greater than every six months and in accordance with the latest edition of NFPA 90A, 92A, local codes and the actuator manufacturer. In addition, fuse links shall be removed and inspected for corrosion. Dry lubricants are recommended.

Specifications are correct at time of printing. However, as part of our 'continuous improvement program,' we reserve the right to make further improvements without notice.

© 1999 NCA Manufacturing



LISTED AND LABELLED BY:



DESIGNED AND TESTED IN ACCORDANCE WITH UL-555 AND ULC-S112. MEETS ALL NFPA-90A REQUIREMENTS FOR FIRE DAMPERS.

Installation:

1. Install damper within fire separation as detailed in the appropriate damper installation instruction sheet. Omit the normal perimeter angles.
2. Place the model FRA angle around the damper sleeve on both sides of the fire separation as shown below.
3. The FRA angles must be attached to the sleeve with No. 10 sheet metal screws, tack or spot welds, 1/4" (6.4 mm) bolts and nuts, or 3/16" (4.8 mm) steel pop rivets.

The fasteners must be spaced 6" (152.4 mm) on centers and be a maximum of 2" (50.8 mm) from the corners.

A minimum of two fasteners is required on each top, bottom or side of the damper sleeve.

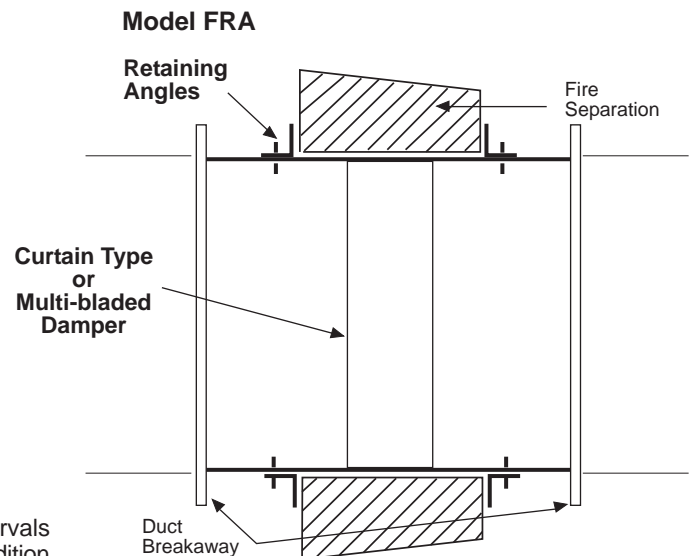

**Vertical installation shown.
Horizontal similar.**

FRA - 02-05 (FRA)

Project:

Contractor:

Location:

Address:

Architect:

P.O. Number:

Engineer:

Date: