



*MODEL O/R
(SINGLE THERMOSTAT OPERATOR RELEASE)
FOR COMBINATION FIRE / SMOKE DAMPERS AND
MOTORIZED MULTI-BLADE FIRE DAMPERS*

In today's life safety products markets, many building codes require fire dampers, smoke dampers and combination fire and smoke dampers to be inspected for proper operation. Many of these codes require that the damper be inspected and cycled every 6 months to a year depending on the local authority and the type of system in which it is installed. Usually fire dampers and combination fire and smoke dampers are supplied with a fusible link. The fusible link is a one time device and is generally limited to 165°F or 212°F. Once the link has experienced these elevated temperatures, it can no longer be used and must be replaced with an identical link. Locating and acquiring the identical fusible link can be troublesome and time consuming. NCA Manufacturing's O/R option provides the ease of operating and resetting the damper in a matter of seconds without replacing is used in lieu of a conventional fusible link. It is a reusable/resettable heat responsive device that can only be reset after a visual inspection of the damper. **Dampers which allow remote resetting of the damper from a remote location are dangerous.** A remotely reset damper may not be fully functional and should be visually inspected. The O/R is reset from the outside of the damper sleeve, when the actuator is externally mounted, therefore requiring a visual inspection of the damper. By depressing a button on the outside of the sleeve and inspector can verify if the damper is fully operational. The O/R is a multi-use heat responsive device. It is wired in series with the smoke detector therefore it is user friendly in most applications. When the smoke detector interrupts the current to the damper, the O/R will not hinder the closing of the damper.



LISTED AND LABELLED BY:



DESIGNED AND TESTED IN ACCORDANCE WITH UL-555 AND ULC-S112. MEETS ALL NFPA-90A REQUIREMENTS FOR FIRE DAMPERS.

The O/R option is available on all NCA Manufacturing FSD Model Combination Fire/Smoke Dampers and Motorized Multi-Blade Fire Dampers. The O/R comes in temperatures of 165°F, 212°F, 250°F and 350°F (depending on actuator selected).

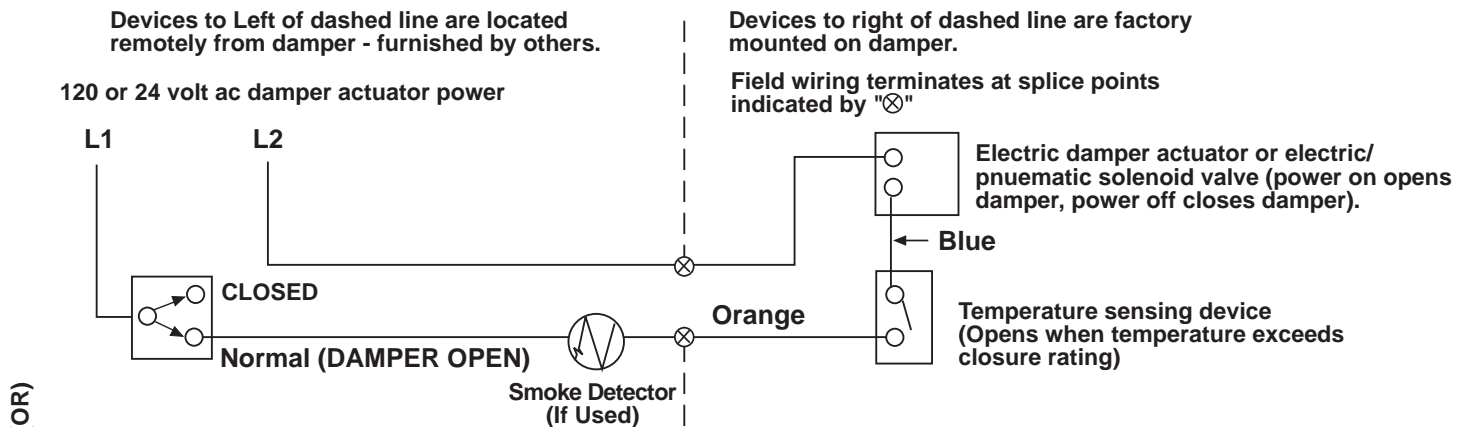

O/R - 02-05 (OR)

FSD DAMPER STO/R OPERATION

Switch is in Normal (Damper Open) Position: Damper motor is energized until thermostat senses temperature above initial closure rating. Above temperature closure rating, the damper motor is de-energized and damper closes.

Smoke Detector (if used) wired in series with temperature sensitive device.

Switch in Closed Position damper motor is de-energized and damper is closed.

Detailed wiring diagrams including terminal designation and/or wire color coding furnished with each shipment.

Thermostat Switch Electrical Limitations

- 15 Ampere, 120 Volts A.C.
- 15 Ampere, 24 Volts A.C.
- 12.5 Ampere, 250 Volts A.C.

Manufacturer's Recommendations

All moving parts of the damper must be inspected and cycled at intervals not greater than every six months and in accordance with the latest edition of NFPA 90A, 92A, local codes and the actuator manufacturer. In addition, fuse links shall be removed and inspected for corrosion. Dry lubricants are recommended.



*MODEL O/R
(SINGLE THERMOSTAT OPERATOR RELEASE)
FOR COMBINATION FIRE / SMOKE DAMPERS AND
MOTORIZED MULTI-BLADE FIRE DAMPERS*

O/R Wiring Details

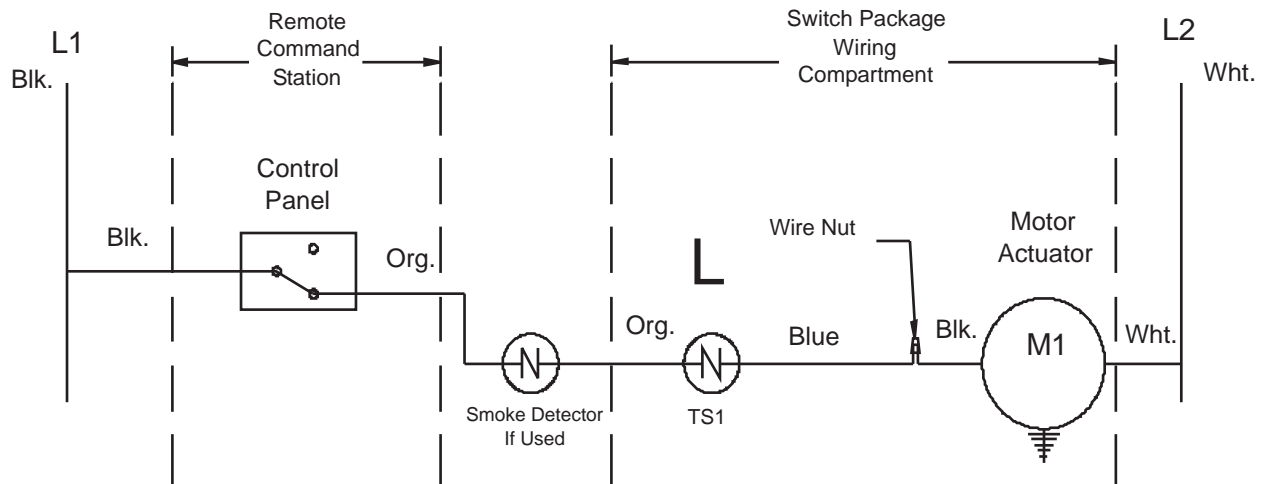

O/R - 02-05 (OR)

