



SUGGESTED DETAILS FOR INSTALLATION AND MAINTENANCE OF NCA LOUVERS

**This document is not intended for Miami-Dade louvers. Please contact factory for detailed Miami-Dade installation instructions.*

© 2003 NCA Manufacturing

When local codes exist they should take precedence over these instructions and maintenance details. Proper documentation of installation and maintenance should be kept to insure validation of warranty and proper operation of a quality product.

Receipt of Shipment: When the louvers arrive, the crate and contents should be inspected for any visible damage and noted on the freight bill. If damage found, cannot be easily repaired on site, then the shipment may be refused for delivery and sent back to the factory as a freight claim for repair. If repair can be done on site, the rep agency or NCA must be contacted immediately to avoid warranty issues. Care and caution should be taken when unloading louvers from crate. Refer to Handling below for proper handling of individual louver. Once louvers are uncrated, check for proper size, finish, frame and blade styles, screens, voltage of actuator (if applicable), and any visual damage. Any discrepancies should immediately be made to rep agency or NCA.

Storage: All louvers, especially adjustable with actuators, shall be stored in a dry area until time for installation. Storage of Louvers in un-protected area, such as outdoors, may cause damage to louver such as finish, adjustable blades, actuators, etc thus voiding any warranty from NCA. Care should be taken to insure louvers are not damaged while in storage.

Transportation/Handling: When removing louvers from crate and transporting them to the area for installation, extreme care needs to be taken. Be careful to lift louvers by frames and not blade. While transporting louver, do not drop, drag, step on, twist, rack, or bow louver. Special Care should be given to assembled multi-section louvers to support the middle section during transportation and installation. Measure and inspect opening to insure it is 1/4" larger than outside dimension of louver. Do not compress or stretch louver into opening.

Recommended Installation of Louvers:

Typical Installation Details Channel Frame and Flush Mount

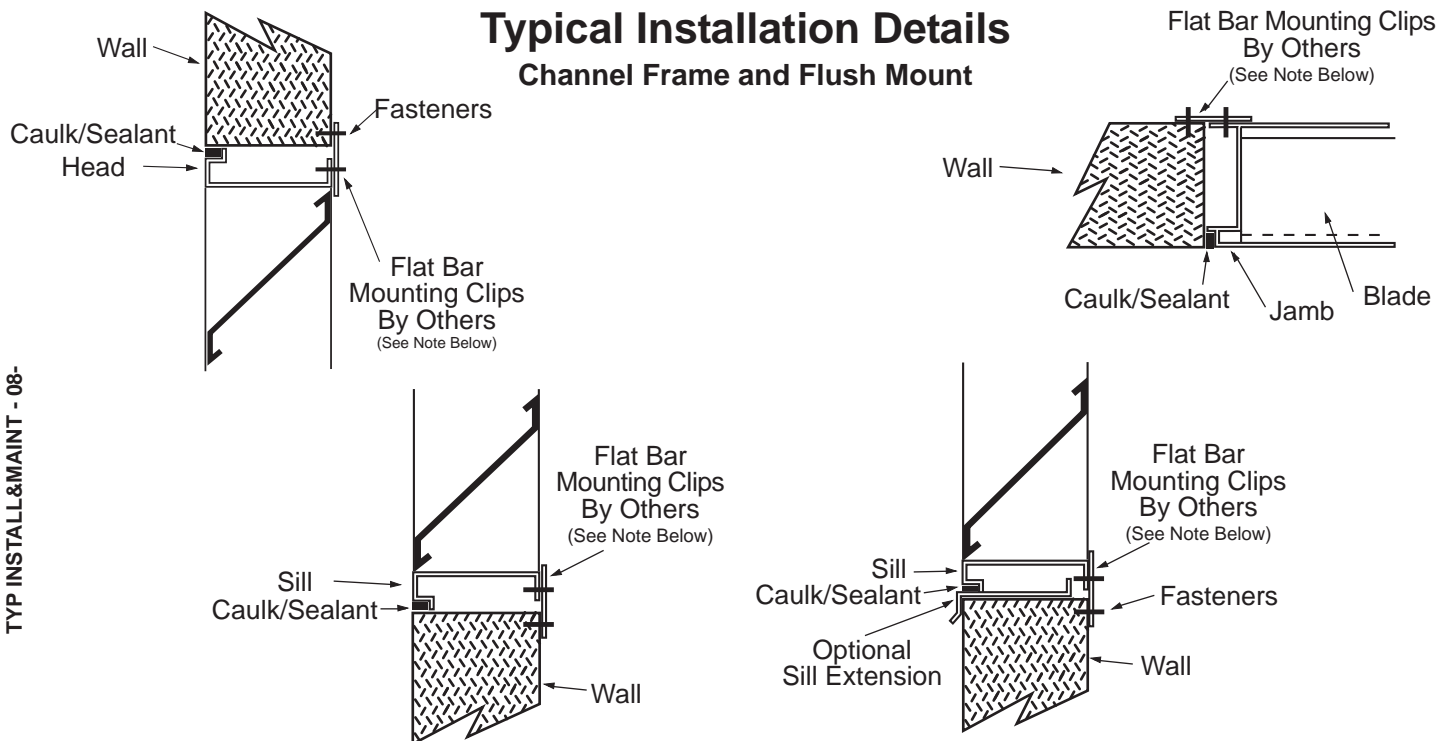

TYP INSTALL & MAINT - 08-

Specifications are correct at time of printing. However, as part of our 'continuous improvement program,' we reserve the right to make further improvements without notice.



SUGGESTED DETAILS FOR INSTALLATION AND MAINTENANCE OF NCA LOUVERS

**This document is not intended for Miami-Dade louvers. Please contact factory for detailed Miami-Dade installation instructions.*

© 2003 NCA Manufacturing

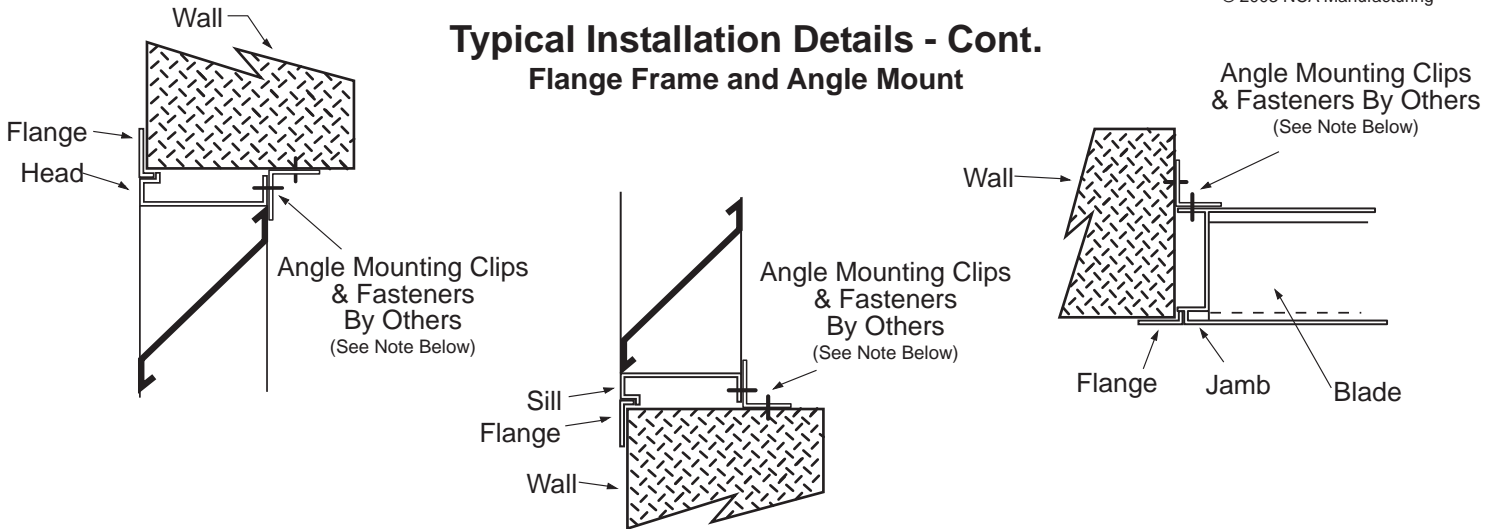

Note: NCA does not recommend fastening through the flange. Apply caulking/sealant to back of flange before installation or to outside perimeter of flange between flange and wall.

Shown above are general mounting arrangements for wall louvers. Because local building codes and installation standards may vary from our recommended minimums, we recommend that they be used over NCA's when and where required. All structural supports, mounting clips/angles, mounting fasteners, sealant/caulk, shims, and anchors are furnished by others. NCA does not provide these as a standard item on louvers. For installation into walls the same thickness as the louver (Flush Mount), NCA recommends the use of 1-1/2" x 1-1/2" x 1/8" mounting plates or flat bar on 24" centers spaced such that there is a minimum of 2 fasteners per side. The recommended mounting in walls thicker than the louver is the use of 1-1/2" x 1-1/2" x 1/8" angle continuous or clips on a minimum of 24" centers, spaced such that there is a minimum of 2 fasteners per side. NCA recommends a minimum of #12 screws when used in wood or steel and 1/4" when used in masonry. The opening shall be square and the sides shall be straight (not bowed). The views shown above should cover most mounting situations encountered. Large multi-panel louvers may require additional structural support on interior of opening which is not provided by NCA.

Maintenance: All louvers should be checked and serviced on a regular basis. In general, stationary louvers require very little maintenance. All louvers should be cleaned with a mild soap solution and rinsed with fresh water on a regular basis, depending on system usage and atmospheric conditions to maintain a good appearance. If any other chemicals are used to clean the surface, be sure to read the instruction carefully to insure no damage is done to the finish. Screens should be checked for build up of debris. Debris between screen and blades could cause water penetration (due to reduced free area), unsightly stains to appear on the face of the louver, or unwanted nesting of animals. The caulk around the louver should be checked for cracking, distortion, shrinkage, etc. Repair or replace any damaged or worn caulking to prevent water intake. Operable and adjustable louvers do require more periodic inspections and maintenance due to moving parts. All connections, fasteners, linkages, pivot points, seals, bearings, swivels, and actuators should be checked for tightness, proper alignment, corrosion, and wear. Replace any worn or corroded parts. Pivot points such as bearings and swivels should be lubricated with a light Moly-Lubricant and excess wiped away to prevent any build up or staining. Check actuator mounting braces to insure they have not broken or loosened, which may cause leakage, vibration or lack of ventilation.

Specifications are correct at time of printing. However, as part of our 'continuous improvement program,' we reserve the right to make further improvements without notice.