



*MODEL OBD-106
OPPOSED BLADE DAMPER*

Standard Construction:

- Frame:** 3-1/2" x 5/8" (88.9 mm x 15.9 mm) x 16 gauge rollformed galvanized steel hat section with welded corners.
- Blades:** 16 ga. rollformed galvanized steel on 6" (152.4 mm) centers.
- Bearings:** Permanently lubricated oilite bronze, press fit into frame.
- Axles:** 1/2" dia. (12.7 mm) plated steel.
- Linkage:** Commercial grade, brass pivots, machine riveted to blade.
- Linkage Tie Rod:** 1/4" dia. (6.4 mm) plated steel.
- Operator Shaft:** 6" x 1/2" dia. (152 mm x 12.7 mm) plated steel.
- Finish:** Mill galvanized.
- Minimum Damper Size:** 6"w x 12"h (152 mm x 304.8 mm)
- Maximum Damper Size:** Single Section: 48"w x 72"h (1,219 mm x 1,828 mm)
Multi Section: unlimited

Options:

- Seals:** Vinyl or stainless steel blade seals
Flexible stainless steel jamb seals
- Operators:** Motor mounting - factory furnished or by others
Manual quadrant
- Finish:** Painted finishes
- Face & Bypass:** Right angle and straight line mixing dampers
- Notes:**

- All dampers are fabricated 1/4" under listed sizes unless specified "actual or exact".
- Dampers must be installed square and free from racking.
- Dampers with multiple sections in both width and height require structural supports (by others). NCA recommends that large openings be divided with structural members such that dampers will span either the width or height of each opening between the structural members with a single section.
- All dampers must be installed with blades running horizontally.
- Connect all damper motors to linkage side of operator blade or to operator shaft.
- Consult factory if application involves static pressures in excess of 2.5 inches w.g.

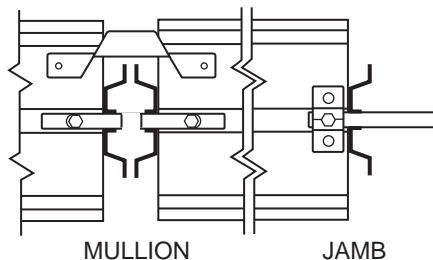
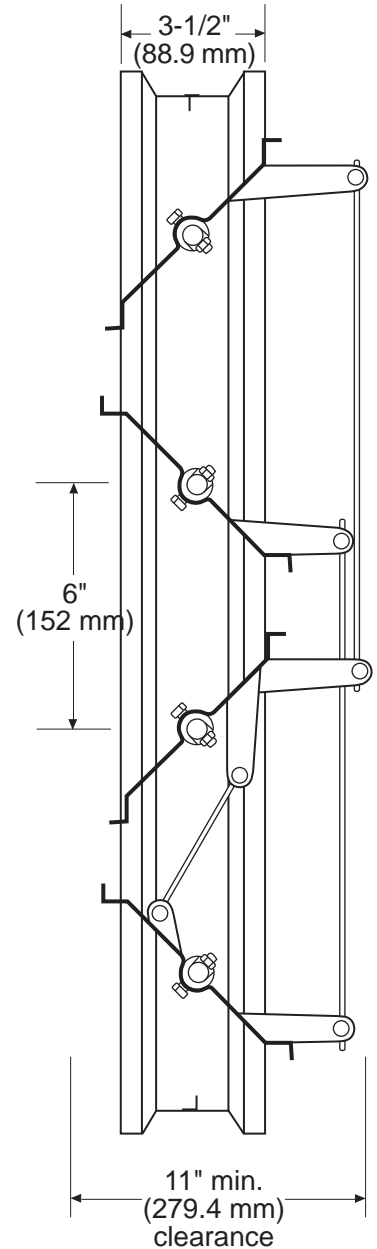

OBD-106 - 03-05

Specifications are correct at time of printing. However, as part of our 'continuous improvement program,' we reserve the right to make further improvements without notice.

© 1999 NCA Manufacturing

Project:	Contractor:
Location:	Address:
Architect:	P.O. Number:
Engineer:	Date:



MODEL OBD-106 OPPOSED BLADE DAMPER

© 1999 NCA Manufacturing

Pressure drop testing was conducted by an independent laboratory in accordance with the AMCA Standard 500-D, Fig. 5.3 ductwork upstream & downstream

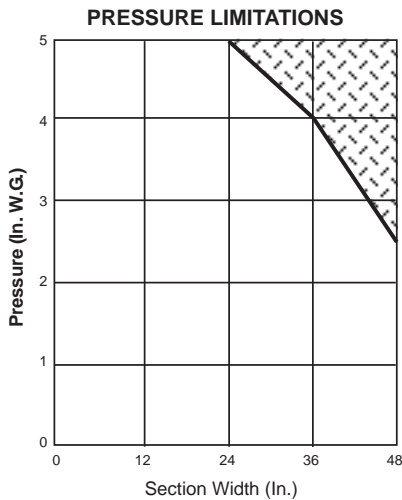
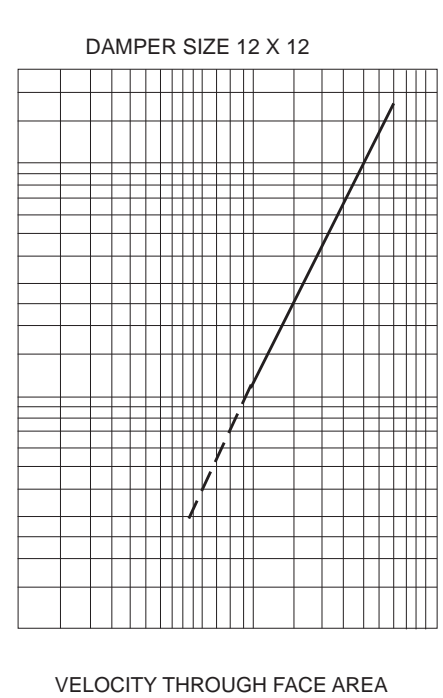
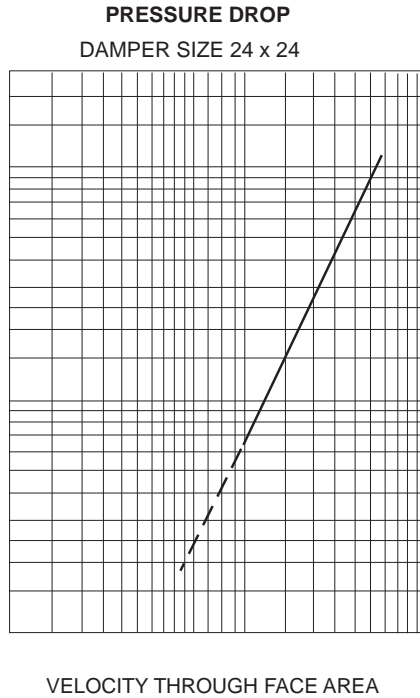
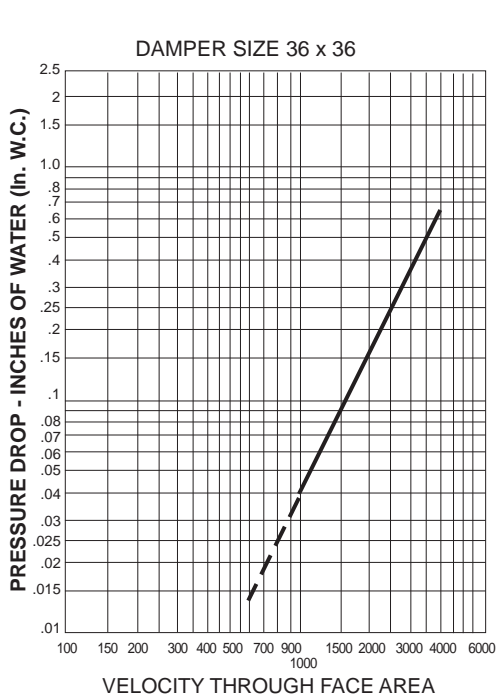

Pressure & Velocity Limitations presented in the adjoining graphs are conservative in order to avoid mis-applications.

Please contact factory for application guidance if your requirements exceed published limitations.

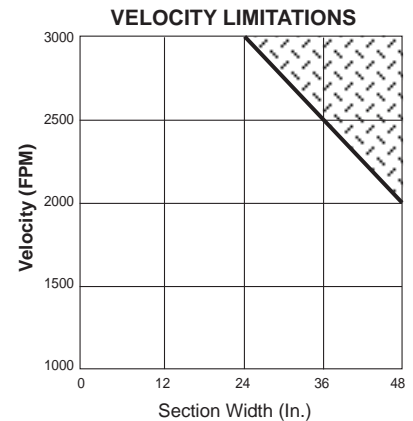

LEAKAGE
DAMPER SIZE 36 x 48

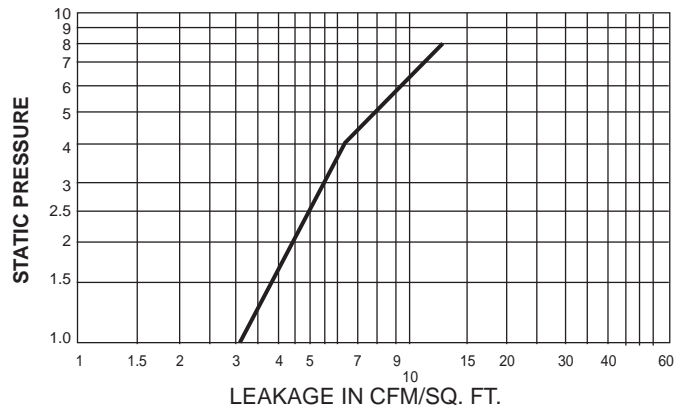

Leakage Performance test was conducted by an independent laboratory in accordance with AMCA Standard 500-D and is expressed as CFM/SQ. FT. of damper face area. Damper requires both blade edge seals and jamb seals to achieve leakage performance depicted.

OBD-106 - 03-05