



**MODEL FSD-AF-S-212 AND MODEL FSD-AF-S-232  
COMBINATION FIRE/SMOKE DAMPER (WITH SLEEVE)**  
U.L. 555 CLASSIFIED 1 1/2 AND 3 HOURS / U.L. 555S CLASSIFIED CLASS II  
LOW PRESSURE DROP AIRFOIL BLADE PER AMCA STANDARD 500-D

**Standard Construction:**

- Frame:** Roll-formed galvanized steel hat-section with staked corners with integral bracing.
- Blades:** Airfoil-shaped, double skin galvanized steel of roll-formed construction. Mechanically joined to form construction equivalent to 14 ga. steel. Minimum width 5" (127 mm) Maximum width 7" (178 mm)
- Bearings:** Bronze Oilite, press-fit into frame.
- Axles:** Square, plated steel.
- Seals:** Pressure sensitive 450°F silicone blade edge seals and flexible metal jamb seals.
- Linkage:** Concealed in frame. Linkage bars are .125" (3.2 mm) thick plated steel.
- Sleeve:** 16" x 20 ga. standard, other gauges and lengths available.

**Heat Responsive Devices:**

**Snap Disk:** 165°F standard, 212°F, 250 F, and 350 F available.

**Finish:** Mill galvanized.

**Sizes:** Minimum Size: 8" w x 8" h (203 mm x 203 mm)  
Maximum UL/ULC Listed Size:  
Single Section: 36" w x 48" h (914 mm x 1219 mm)

**1-1/2 Hr. Vertical:** Multiple Assembly-108" w x 96" h (2743 mm x 2438 mm)

**1-1/2 Hr. Horizontal:** Multiple Assembly-36" w x 48" h (914 mm x 1219 mm)

**3 Hr. Vertical:** Multiple Assembly-72" w x 96" h (1828 mm x 2438 mm)

**3 Hr. Horizontal:** Maximum UL/ULC Listed Size: 36" w X 48" h (914mm x 1219mm)

**Maximum Velocity:** 2000 fpm (10.2 m/s) on all sizes

**Maximum Pressure:** 4" wg (1kPa)

**Consult Factory** for Limitations up to 4000 fpm @ 6" wg.

- Notes:**
- Sleeved dampers are furnished approx. same size as given duct dimension, unless otherwise noted.
  - Not recommended with blades running vertically.



**Features**

- The FSD-AF-S-2X2 series Combination Fire/Smoke Dampers have been designed and tested to provide a complete range of performance features when used in engineered smoke control systems.
- FSD-AF-212 is U.L. 555 and U.L.C. S112 listed and labeled as a 1-1/2 hour fire damper.
- FSD-AF-232 is U.L. 555 and U.L.C. S112 listed and labeled as a 3 hour fire damper.
- U.L. 555S and U.L.C. S112.1 listed and labelled as a Leakage Class II rated Smoke Damper with airflow in both directions. Class II provides for a maximum leakage of 20 cfm per sq. ft. at 4.0 inches static pressure. As we are constantly expanding our U.L./U.L.C. listings, we suggest you contact the factory for current information.
- Streamlined "airfoil" blades to provide low pressure drop and reduced air turbulence for quiet operation.
- The snap disk is a reusable/resettable heat response device that can be reset after visual inspection of the damper. Also available Model STO/R (single thermostat) and DTO/R (dual thermostat) to provide the fire fighter with complete discretionary control of smoke functions during a fire/smoke emergency. (See **STO/R and DTO/R submittal drawings for complete details**). Spring return type damper motor controlled by a smoke detector is recommended to provide proper operation in the smoke mode.
- Available are options EGF (Electric Globe Fuse Link) and PFV (Pneumatic Fusible Valve). These options provide visible fuse links with a quick and economical ways to check damper operations while also providing a Systematic Closure Control. Option PFV allows damper operation without the need/cost for an E-P valve and electrical connection at the damper.
- Available optional 3/4" flanged sleeve for grille mounting (see fig.9 of installation instructions). If actuator is to be externally mounted, it is suggested to order flange to be field installed.

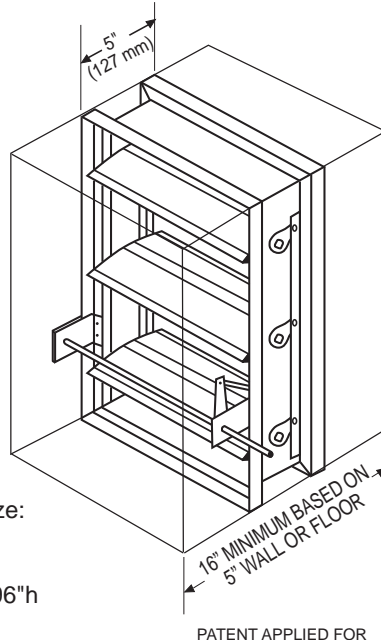

**Suggested Specification**

Combination Fire/Smoke Dampers shall be Model: FSD-AF-S-212 by NCA Manufacturing. Damper blades shall be of double-skinned streamlined ("airfoil") construction for minimum pressure drop. Single blade edge and jamb seals shall be of the pressure sensitive type for low leakage. Dampers shall be rated for both Fire Damper (U.L. 555S/U.L.C. S112) and Smoke Damper (U.L. 555S/U.L.C. S112.1) operation. Leakage shall not exceed 20 cfm per sq. ft. at 4.0" static pressure. Linkage shall be of the concealed type for maximum free area. Dampers shall bear the Underwriters' Laboratories labels.

**Manufacturer's Recommendations**

All moving parts of the damper must be inspected and cycled at intervals not greater than every twelve months or in accordance with the latest edition of NFPA 80, 90A, 92A, local codes and the actuator manufacturer. In addition, the damper shall be inspected for corrosion. Dry lubricants are recommended.

© 2007 NCA Manufacturing

FSD-AF-S-212 - 09-07

Project:  
Location:  
Architect:  
Engineer:

Contractor:  
Address:  
P.O. Number:  
Date:



**MODEL FSD-AF-S-212 AND MODEL FSD-AF-S-232  
COMBINATION FIRE/SMOKE DAMPER (WITH SLEEVE)**  
U.L. 555 CLASSIFIED 1 1/2 AND 3 HOURS / U.L. 555S CLASSIFIED CLASS II  
LOW PRESSURE DROP AIRFOIL BLADE PER AMCA STANDARD 500-D

**PERFORMANCE DATA**

© 2007 NCA Manufacturing

Pressure drop testing was done by an independent laboratory to the AMCA Standard 500-D, Fig. 5.3 ductwork upstream & downstream.

**DAMPER SIZE 36 x 36**

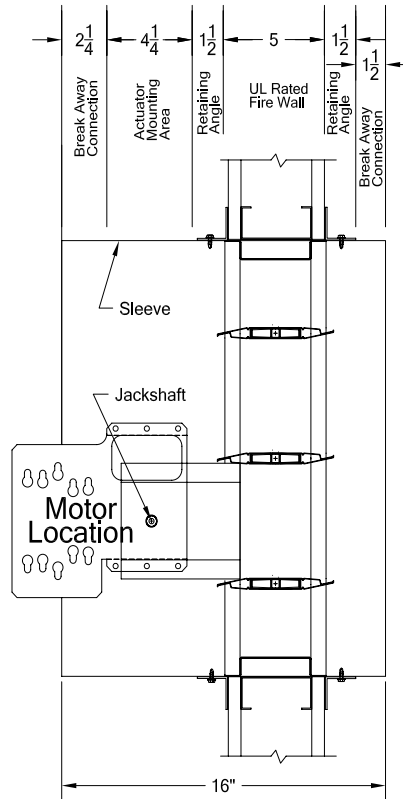
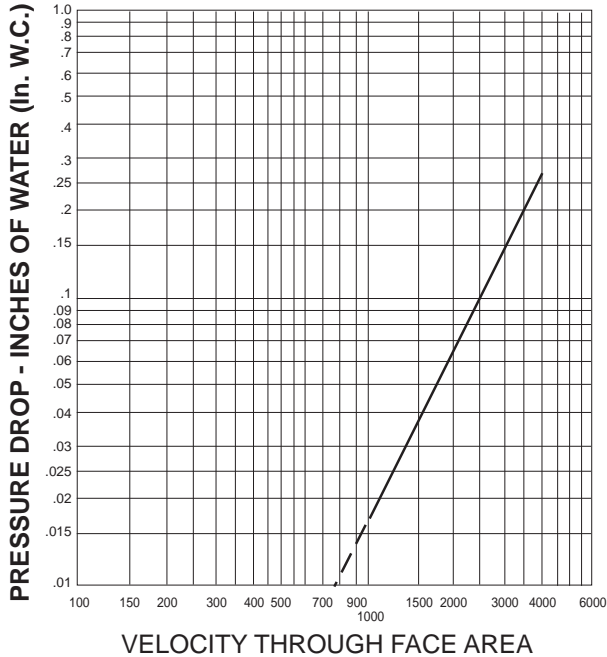

When the actuator is externally mounted and the wall thickness exceeds 5 inches, add 1 inch for each additional inch of wall thickness increased to ensure sleeve length through the penetration.

As standard the actuator is externally installed on the lower right hand half of the damper when viewed from the jack shaft side. The damper may be installed/rotate 180° such the actuator will be located on the upper left. The top of the damper is either side of the frame as long as the blades are running parallel.

When ordering internally mounted actuators, be aware there is a min. height requirement (in some cases the sleeve can be increased to allow for internally mounting).

The entire damper frame does not have to be installed in the plane of the wall of floor. The rule of thumb is with the damper in the closed position, the blade plane should be within the plane of the UL rated wall or floor.

**DAMPER SIZE 24 x 24**

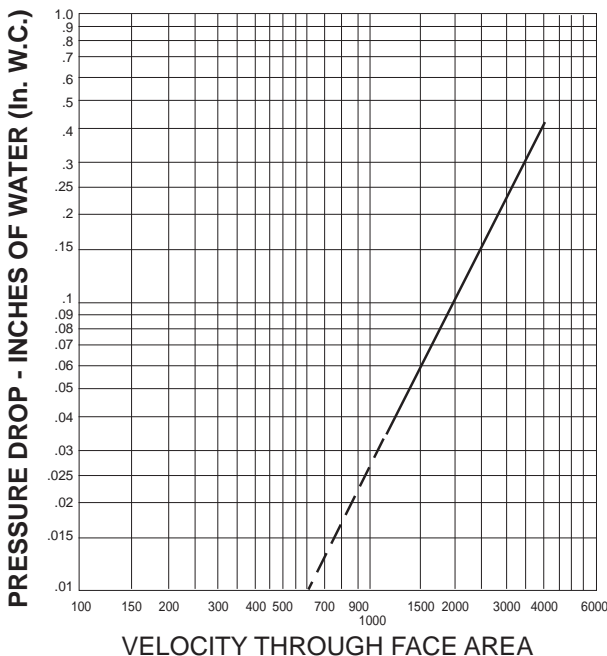

**DAMPER SIZE 12 x 12**

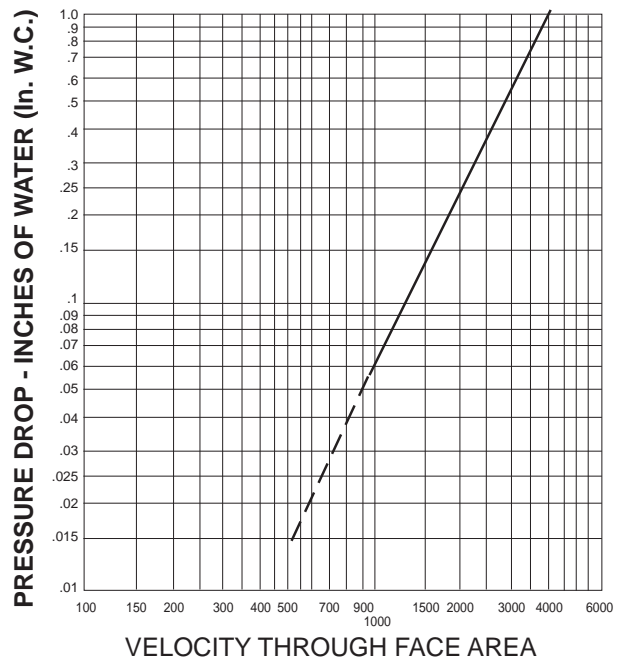

FSD-AF-S-212 - 09-06