



**MODEL SSD-AF-201**  
**LOW LEAKAGE SMOKE DAMPER**  
**U.L. 555S CLASSIFIED / CLASS I**  
**LOW PRESSURE DROP: AIRFOIL BLADE PER AMCA 500-D**

**U.L. 555S CLASSIFIED**  
**AT 250°F OR 350°F**  
**DEPENDENT UPON**  
**MOTOR/OPERATOR**  
\*SEE MOTOR/OPERATOR SCHEDULE

**Standard Construction:**

- Frame:** Roll-formed galvanized steel hat-section with staked corners with integral bracing.
- Blades:** Airfoil-shaped, double skin galvanized steel of roll-formed construction. Mechanically joined to form construction equivalent to 14 ga. steel.  
 Minimum width: 5" (127 mm)  
 Maximum width: 7" (179 mm)
- Bearings:** Bronze Oilite, press-fit into frame.
- Axles:** Square, plated steel.
- Seals:** Pressure sensitive 450°F silicone blade edge seals and flexible metal jamb seals.
- Linkage:** Concealed in frame. Linkage bars are .125" (3.2 mm) thick plated steel.
- Finish:** Mill galvanized.
- Sizes:** Minimum Size: 8"w x 8"h. (203 mm x 203 mm)  
 Maximum UL Listed Size:  
 Single Section: 36"w x 48"h (914 mm x 1219 mm)  
 Multi-Section: 144"w x 96"h (3657 mm x 2438 mm)

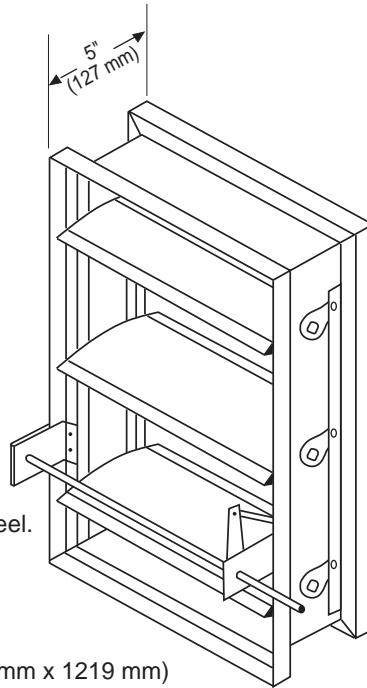

PATENT APPLIED FOR

**Maximum Velocity:** 2000 fpm (10.2 m/s) on all sizes

**Maximum Pressure:** 4" w.g. (1kPa)

**Consult Factory** for Limitations up to 4000 fpm (20.4 m/s) @ 6" w.g. (1.5kPa)

- Notes:**
- Non-Sleeved and IT Plate dampers are furnished approximately 1/4" (6.4 mm) smaller than given duct dimensions. Sleeved dampers are furnished approx. same size as given duct dimension, unless otherwise noted.
  - Not recommended with blades running vertically.

**Suggested Specification**

Low Leakage Smoke Control Damper shall be Model: SSD-AF-201 by NCA Manufacturing. Damper blades shall be of streamlined ("airfoil") construction for minimum pressure drop. Both blade edge and jamb seals shall be of the pressure sensitive type for low leakage. Dampers shall be rated for leakage as to U.L. 555S and U.L.C. S112.1. Pressure Drop data is to be per AMCA 500-D. Leakage shall not exceed 8 cfm per sq. ft. at 4.0" static pressure. Linkage shall be of the concealed type for maximum free area. Dampers shall bear the Underwriters' Laboratories label.

**Manufacturer's Recommendations**

All moving parts of the damper must be inspected and cycled at intervals not greater than every twelve months or in accordance with the latest edition of NFPA 80, 90A, 92A, local codes and the actuator manufacturer. In addition, the damper shall be inspected for corrosion. Dry lubricants are recommended.

Specifications are correct at time of printing. However, as part of our 'continuous improvement program,' we reserve the right to make further improvements without notice.

© 2005 NCA Manufacturing



LISTED AND LABELLED BY:



**Features**

- The SSD-AF-201 series Smoke Dampers have been designed and tested to exceed all U.L., U.L.C. and N.F.P.A. requirements for smoke dampers. These U.L. leakage rated dampers are intended for use in engineered smoke control systems to provide low pressure drop (open position) and extremely tight shut-off (closed position).
- U.L. 555S and U.L.C. S112.1 listed and labelled as Leakage Class I rated Smoke Damper with airflow in both directions. Class I provides for a maximum leakage of 8 cfm per sq. ft. at 4 inch static pressure. As we are constantly expanding our U.L./U.L.C. listings, we suggest you contact the factory for further information.
- Streamlined "airfoil" blades to provide low pressure drop and reduced air turbulence for quiet operation.
- The SSD-AF-201 exceeds N.F.P.A. 90A & 92 smoke damper requirements and is recommended for applications that call for tight sealing requirements. The SSD-AF-201 provides excellent control of smoke movement or containment as the smoke management system demands.
- The SSD-AF-201 may be equipped with factory installed electric or pneumatic operators.

SSD-AF-201 - 10-05

Project:

Contractor:

Location:

Address:

Architect:

P.O. Number:

Engineer:

Date:



*MODEL SSD-AF-201  
LOW LEAKAGE SMOKE DAMPER  
U.L. 555S CLASSIFIED / CLASS I  
LOW PRESSURE DROP: AIRFOIL BLADE PER AMCA 500-D*

© 2005 NCA Manufacturing

## PERFORMANCE DATA

Pressure drop testing was done by an independent laboratory to AMCA Standard 500-D, Fig. 5.3 ductwork upstream & downstream.

DAMPER SIZE 36 x 36

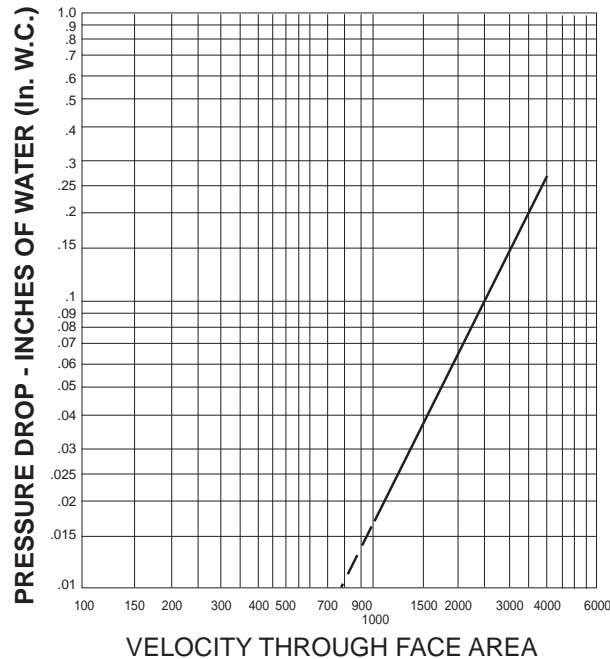

DAMPER SIZE 24 x 24

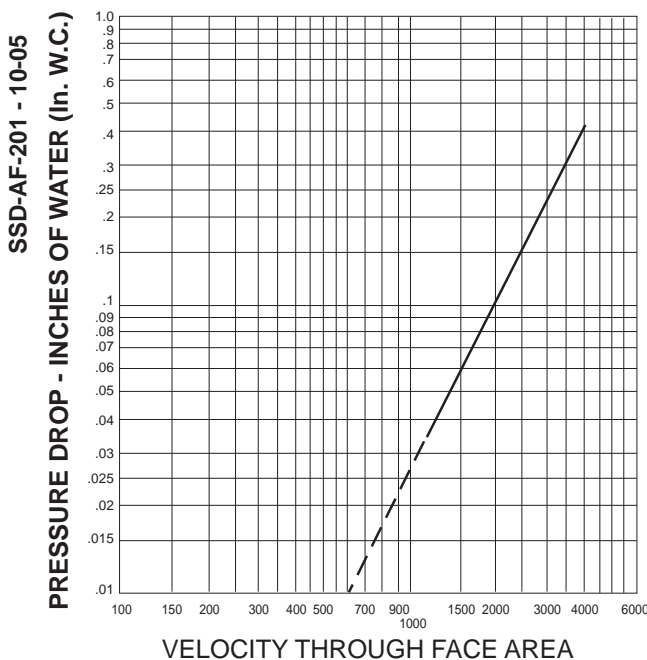

DAMPER SIZE 12 x 12

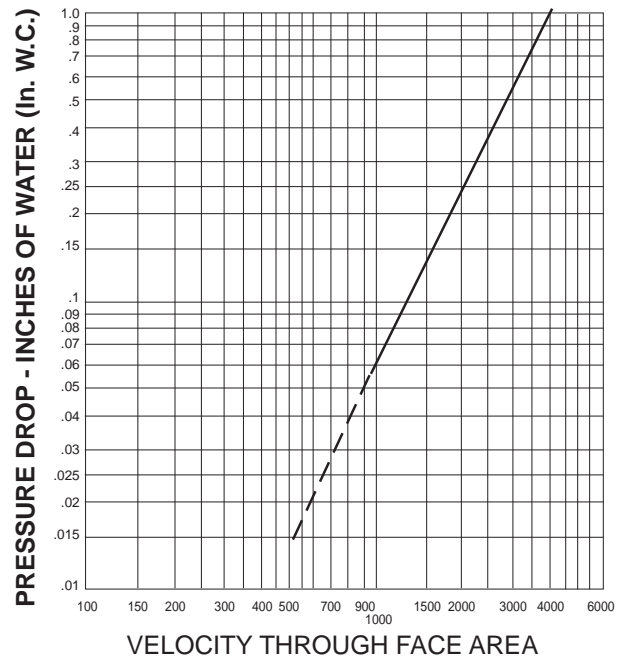

SSD-AF-201 - 10-05