



**MODEL SSD-RD-202 TRUE ROUND
LOW LEAKAGE SMOKE DAMPER
U.L. 555S CLASSIFIED / CLASS II**

**U.L. 555S CLASSIFIED
AT 250°F OR 350°F
DEPENDING UPON
MOTOR/OPERATOR
*SEE MOTOR/OPERATOR SCHEDULE**



LISTED AND LABELLED BY:



Standard Construction:

- Frame:** Roll-formed galvanized steel, 16" (406 mm) long, integral sleeve.
- Blades:** Double thickness galvanized steel, 14 ga. equivalent with welded channel re-inforcement.
- Bearings:** Bronze Oilite press-fit into frame.
- Axles:** 3/8" (9.5 mm) square plated steel.
- Jackshaft:** 1/2" (12.7 mm) diameter plated steel.
- Seals:** Pressure sensitive 450°F silicone sandwiched between blades.
- Linkage:** Jackshaft to blade.
- Finish:** Mill galvanized.
- Sizes:** 8" - 24" (203 mm - 610 mm) diameter

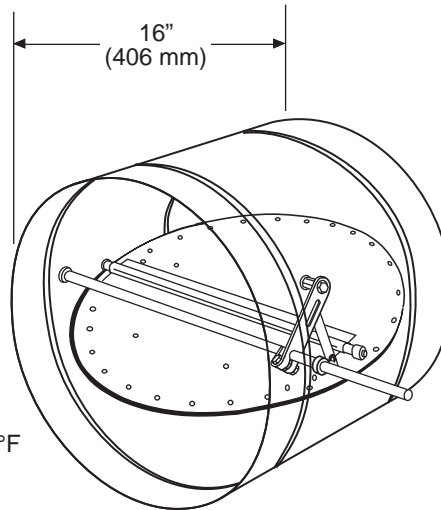

FEATURES

- The SSD-RD-202 Smoke Dampers have been designed and tested to exceed all U.L., U.L.C., and N.F.P.A. requirements for smoke dampers. These U.L. leakage rated dampers are intended for use in engineered smoke control systems to provide extremely tight shut off.
- U.L. 555 and U.L.C. S112 listed and labelled as a Leakage Class II rated Smoke Damper with 2,000 FPM airflow in both directions. Class II provides for a maximum leakage of 20 cfm per sq. ft. at 4.0 inches static pressure. As we are constantly expanding our U.L./U.L.C. listings, we suggest you contact the factory for current information.
- The SSD-RD-202 exceeds N.F.P.A. 90A & 92 smoke damper requirements and is recommended for applications that call for tight sealing requirements. The SSD-RD-202 provides excellent control of smoke movement or containment as the smoke management system demands.
- The SSD-RD-202 must be equipped with factory installed electric or pneumatic operators.

Maximum Velocity: 2000 fpm (10.2 m/s)
Maximum Pressure: 4" w.g. (1kPa)

Note: Dampers are furnished approximately 1/8" (3.2 mm) smaller than given duct dimensions.

SUGGESTED SPECIFICATION:

Round Low Leakage Smoke Control Damper shall be Model: SSD-RD-202 by NCA Manufacturing. Damper blade shall be of galvanized steel with channel reinforcement. Blade edge seals shall be of the pressure sensitive, high temperature type for low low leakage. Dampers shall be rated for low leakage in accordance with U.L. 555S / U.L.C. S112.1 and shall bear the Underwriters' Laboratories label for Class II. Leakage shall not exceed 20 cfm per sq. ft.. at 4.0 inches static pressure. Units shall also be listed to operate at a minimum of 2,000 FPM at 350°F (177°C). Unit shall have factory installed actuator.

Manufacturer's Recommendations

All moving parts of the damper must be inspected and cycled at intervals not greater than every twelve months or in accordance with the latest edition of NFPA 80, 90A, 92A, local codes and the actuator manufacturer. In addition, the damper shall be inspected for corrosion. Dry lubricants are recommended.

Specifications are correct at time of printing. However, as part of our 'continuous improvement program,' we reserve the right to make further improvements without notice.

© 2007 NCA Manufacturing

SSD-RD-202 - 07-07

Project: _____ Contractor: _____
 Location: _____ Address: _____
 Architect: _____ P.O. Number: _____
 Engineer: _____ Date: _____



MODEL SSD-RD-202 TRUE ROUND SMOKE DAMPER PERFORMANCE DATA

© 2007 NCA Manufacturing

Pressure drop testing was done by an independent laboratory to AMCA Standard 500-D, Fig. 5.3 ductwork upstream & downstream.

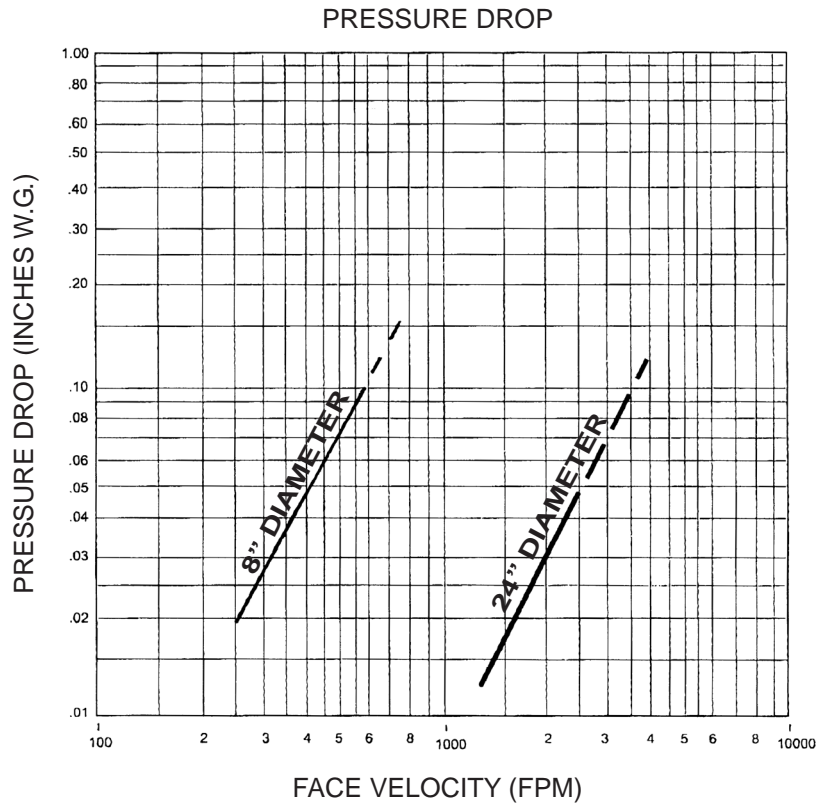

SSD-RD-202 - 02-06

LEAKAGE OBTAINED IN TEST OF 8" DIAMETER AND 24" DIAMETER
WAS LESS THAN 1 CFM/SQ. FT.