

Tag: _____ Engineer: _____
 Project: _____ Contractor: _____
 Location: _____ Architect: _____
 Date: _____ Submitted by: _____



Model FDD

Dynamic Curtain Fire Damper
 1-1/2 or 3 Hour, UL555 Listed

Application:

The NCA model FDD fire damper utilizes a curtain style blade to prevent the spread of fire through a penetration in a fire rated barrier made by an HVAC duct or transfer. The FDD can be installed vertically (FDD-V) or horizontally (FDD-H) and is meant for dynamic (fans remain on in a fire) or static (fans shut off in a fire) HVAC systems.

MAXIMUM VELOCITY: 2000 fpm (10.2 m/s) on all sizes.

MAXIMUM PRESSURE: 4" wg (1kPa) on all sizes.

Standard Construction:

	Standard	Optional
Frame Material	22 Gauge Galvanized Roll-formed Steel	-----
Blade Material and Type	22 Gauge Galvanized Roll-formed Steel	-----
Frame Depth	3-11/16" (94)	2-3/8" (55) [see Model FDD-SL]
Dimensions	Actual - 1/4" (6)	Actual
Closure Spring	Stainless Steel	-----
Fusible Link	165° (74°C)	212° (100°C)
Mounting	Vertical [FDD-V]	Horizontal [FDD-H]
UL Hour Rating	1-1/2 Hour	3 Hour

All dimensions shown in inches, parentheses () indicate millimeters.

Optional Construction:

3-Hour Rating

212° Fusible Link

Factory Supplied Welded Sleeve:

Length: 12 (305) 16 (406) 24 (610) Other: _____

Gauge: 20 (1.0) 18 (1.3) 16 (1.6) 14 (2.0) 10 (3.5)

Location in Sleeve: Standard Offset: _____

Factory Supplied Integral Sleeve (20 gauge only):

Length: 12 (305) 14 (356) 16 (406)

Flanged Sleeve (requires factory welded sleeve):

3/4" (19) 1" (25)

Framed Retaining Angles - 16 ga. x 1 1/2 x 1 1/2 (1.6x38x38)

Single Side Dual Side

Sealed Sleeve (Factory welded sleeve only)

Fully Welded Fully Caulked

Other Options:

- Access Doors (see Model ADH)
- Static models (see Model FD)
- Integral Sleeve models (see Model FDD-S)
- Multi-Blade models (see Model FDD-MB)
- Slimline models (see Models FDD-SL)
- Out-of-Wall models (see Model FDD-OW)
- True Round models (see Model FDD-RD)



LISTINGS:

UL 555 Listing: R8218

CSFM Listing: 3225-1721:0102

New York MEA Listing: 79-03-M

STANDARDS MET:

NFPA Standards: 80, 90A, 92A, 92B and 101

Building Code Standard:

ICC International Building Code

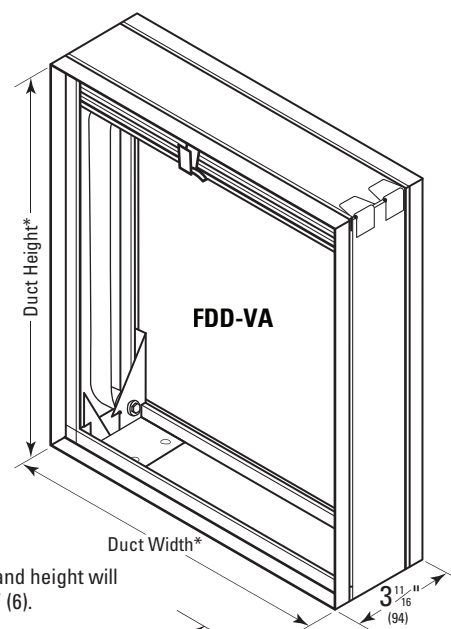

*Damper width and height will be undercut 1/4" (6).

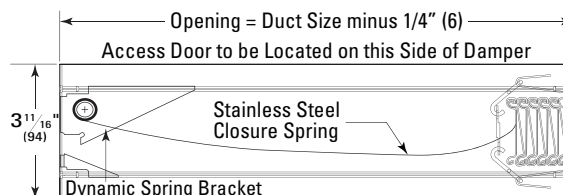
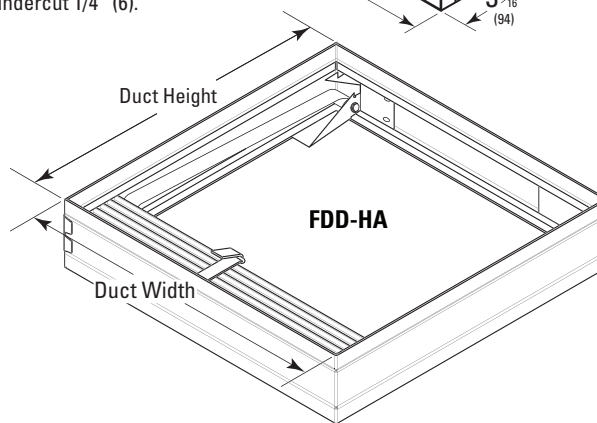

FDD-HA Shown (FDD-VA Similar)

As part of our continuous improvement program, we reserve the right to make further improvements without notice.

Submittal - Model FDD - 0120



DAMPER STYLES & SIZES - Model FDD

Dynamic Curtain Fire Damper

Type A Dynamic Curtain Fire Damper

- For use in dynamic HVAC systems (fans on)
- Frame and blade stack in air stream
- Approximately 75-85% Free Area
- Sleeve optional (Factory welded or Integral)
- 1-1/2 or 3 Hour Fire Rated

FDD-A Minimum & Maximum Sizes:

Type A Model	Minimum Size		Max. Single Section		Max. Multi-Section	
	1.5 Hour	3 Hour	1.5 Hour	3 Hour	1.5 Hour	3 Hour
FDD-VA (Vertical)	6x6 (152x152)		36x36 (914x914)	36x36 (914x914)	72x36 (1829x914) 36x72 (914x1829)	72x36 (1829x914) 36x72 (914x1829)
FDD-HA (Horizontal)			24x24 (610x610)	24x24 (610x610)	36x36 (914x914)	36x36 (914x914)

All dimensions shown in inches, parentheses () indicate millimeters.

A Dimension = Duct Width

B Dimension = Duct Height

Notes:

1. Integral sleeves are only offered in 20 gauge and in 12" (305), 14" (356) and 16" (406) lengths.

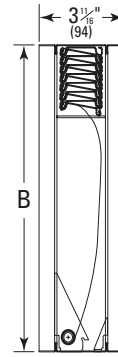

Type A without Sleeve

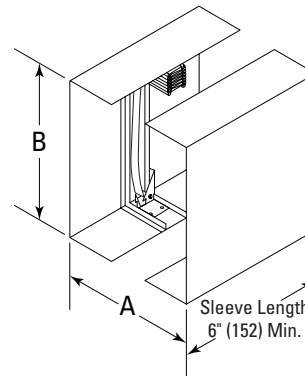
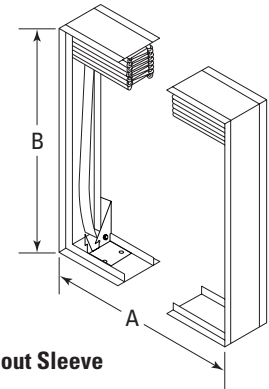

Type A with Welded Sleeve

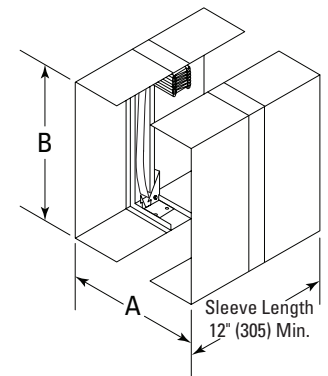

Type A with Integral Sleeve¹

Type B Dynamic Curtain Fire Damper

- For use in dynamic HVAC systems (fans on)
- Blade stack out of airstream
- Approximately 80-90% Free Area
- Sleeve optional (Factory welded or Integral)
- 1-1/2 or 3 Hour Fire Rated

FDD-B Minimum & Maximum Sizes:

Type B Model	Minimum Size		Max. Single Section		Max. Multi-Section ²	
	1.5 Hour	3 Hour	1.5 Hour	3 Hour	1.5 Hour	3 Hour
FDD-VB (Vertical)	6x4 (152x102)		36x32 (914x813)	36x32 (914x813)	72x32 (1829x813) 36x68 (914x1727)	72x32 (1829x813) 36x68 (914x1727)
FDD-HB (Horizontal)			24x21 (610x533)	24x21 (610x533)	36x32 ³ (914x813)	36x32 ³ (914x813)

All dimensions shown in inches, parentheses () indicate millimeters.

A Dimension = Duct Width

B Dimension = Duct Height

X Dimension = Height of Blade Stack

H Dimension = Overall Damper Height (B+X)

Notes:

1. Integral sleeves are only offered in 20 gauge and in 12" (305), 14" (356) and 16" (406) lengths.
2. Multi-section dampers will have frame in the airstream, and blades for vertical models more than one damper high.
3. Note special construction on Multiple Section page in this submittal.

As part of our continuous improvement program, we reserve the right to make further improvements without notice.

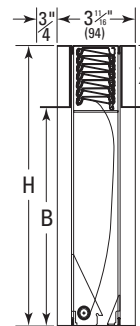

Type B without Sleeve

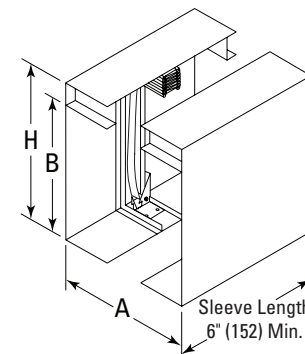
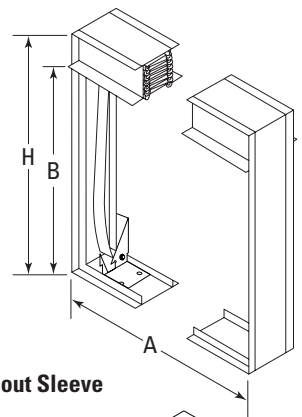

Type B with Welded Sleeve

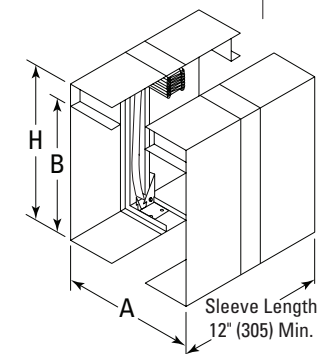

Type B with Integral Sleeve¹

Submittal - Model FDD - 0120



DAMPER STYLES & SIZES - Model FDD

Dynamic Curtain Fire Damper

Type C Dynamic Curtain Fire Damper

Square or Rectangular Transition

- For use in dynamic HVAC systems (fans on)
- Frame and blade stack out of airstream
- Approximately 95-100% Free Area
- Sleeve optional (Factory welded or Integral)
- 1-1/2 or 3 Hour Fire Rated

FDD-C Minimum & Maximum Sizes:

Type C Model	Minimum Size		Max. Single Section		Max. Multi-Section ²	
	1.5 Hour	3 Hour	1.5 Hour	3 Hour	1.5 Hour	3 Hour
FDD-VC (Vertical)	5x3 (127x76)		35x31 (889x787)	35x31 (889x787)	71x31 (1803x787) 35x67 (889x1702)	71x31 (1803x787) 35x67 (889x1702)
FDD-HC (Horizontal)			23x20 (584x508)	23x20 (584x508)	35x32 (889x813)	35x32 (889x813)

All dimensions shown in inches, parentheses () indicate millimeters.

A Dimension = Duct Width

B Dimension = Duct Height

X Dimension = Height of Blade Stack

H Dimension = Overall Damper Height (B+X+1")

Notes:

1. Integral sleeves are only offered in 20 gauge and in 12" (305), 14" (356) and 16" (406) lengths.
2. Multi-section dampers will have frame in the airstream, and blades for vertical models more than one damper high.

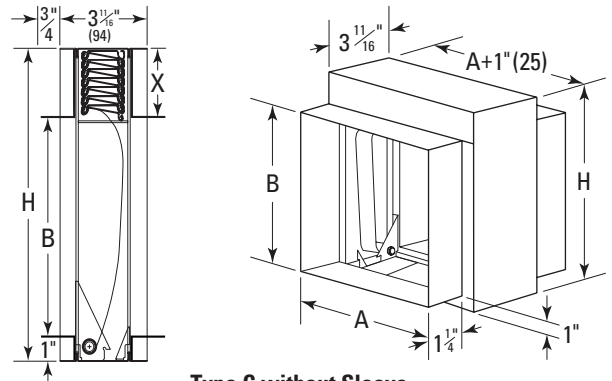

Type C without Sleeve

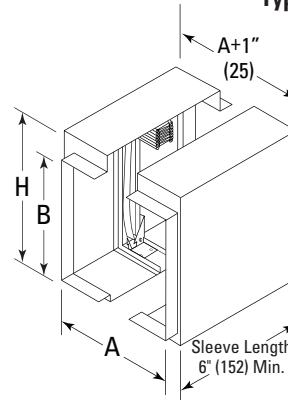

Type C with Welded Sleeve

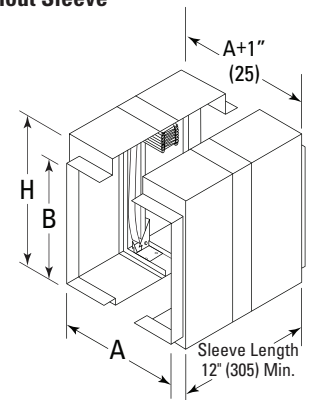

Type C with Integral Sleeve¹

Type C Dynamic Curtain Fire Damper

Oval Transition

- For use in dynamic HVAC systems (fans on)
- Frame and blade stack out of airstream
- Approximately 95-100% Free Area
- Sleeve optional (Factory welded or Integral)
- 1-1/2 or 3 Hour Fire Rated

FDD-C-O Minimum & Maximum Sizes:

Oval Type C Model	Minimum Size		Max. Single Section		Max. Multi-Section ²	
	1.5 Hour	3 Hour	1.5 Hour	3 Hour	1.5 Hour	3 Hour
FDD-VC-O (Vertical)	5x3 (127x76)		35x31 (889x787)	35x31 (889x787)	71x31 (1803x787) 35x67 (889x1702)	71x31 (1803x787) 35x67 (889x1702)
FDD-HC-O (Horizontal)			23x20 (584x508)	23x20 (584x508)	35x32 (889x813)	35x32 (889x813)

All dimensions shown in inches, parentheses () indicate millimeters.

A Dimension = Duct Width

B Dimension = Duct Height

X Dimension = Height of Blade Stack

H Dimension = Overall Damper Height (B+X+1")

Notes:

1. Integral sleeves are only offered in 20 gauge and in 12" (305), 14" (356) and 16" (406) lengths.
2. Multi-section dampers will have frame in the airstream, and blades for vertical models more than one damper high.

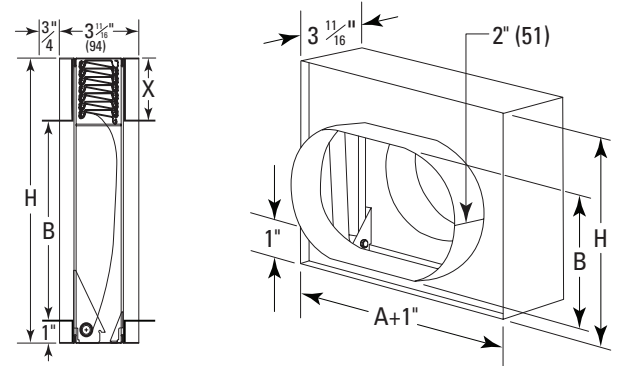

Type C-O without Sleeve

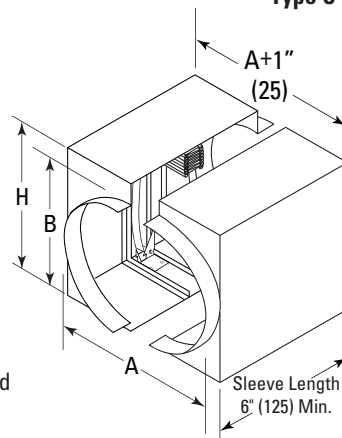

Type C-O with Welded Sleeve

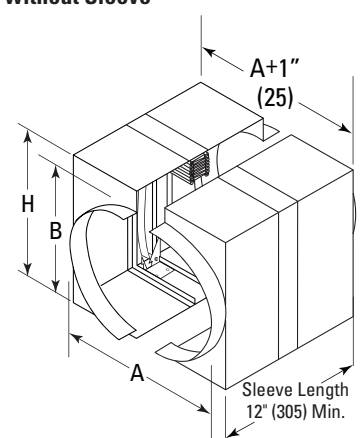

Type C-O with Integral Sleeve¹

As part of our continuous improvement program, we reserve the right to make further improvements without notice.

Submittal - Model FDD - 0120



DAMPER STYLES & SIZES - Model FDD

Dynamic Curtain Fire Damper

Type C Dynamic Curtain Fire Damper Round Transition

- For use in dynamic HVAC systems (fans on)
- Frame and blade stack out of airstream
- Approximately 95-100% Free Area
- Sleeve optional (Factory welded or Integral)
- 1-1/2 or 3 Hour Fire Rated

FDD-RC Minimum & Maximum Sizes:

Round C Model	Minimum Size		Max. Single Section		Max. Multi-Section ²	
	1.5 Hour	3 Hour	1.5 Hour	3 Hour	1.5 Hour	3 Hour
FDD-RVC (Vertical)	4" Dia. (102)		32" Dia. (813)	32" Dia. (813)	32" Dia. (813)	32" Dia. (813)
FDD-RHC (Horizontal)			20" Dia. (508)	20" Dia. (508)	32" Dia. (813)	32" Dia. (813)

All dimensions shown in inches, parentheses () indicate millimeters.

X Dimension = Height of Blade Stack

H Dimension = Overall Damper Height (D+X+1")

D Dimension = Diameter

Notes:

1. Integral sleeves are only offered in 20 gauge and in 12" (305), 14" (356) and 16" (406) lengths.
2. Multi-section dampers will have frame in the airstream, and blades for vertical models more than one damper high.

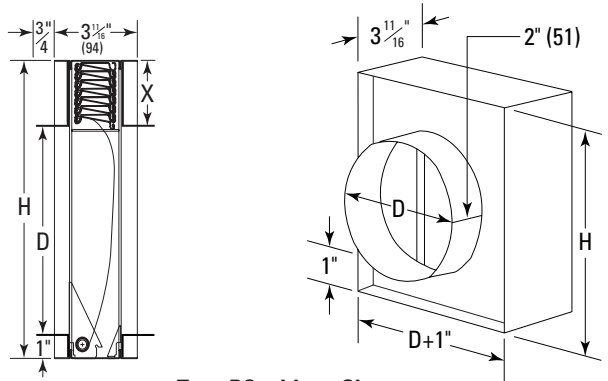

Type RC without Sleeve

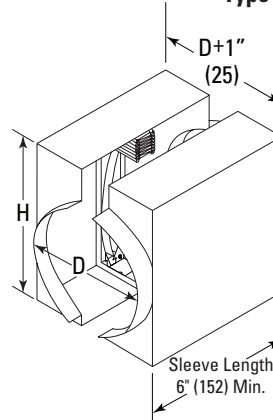

Type RC with Welded Sleeve

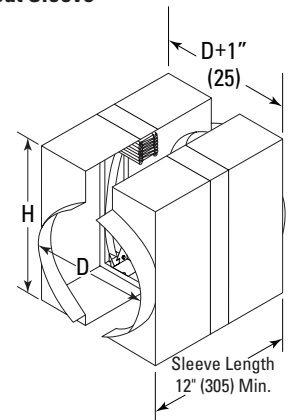

Type RC with Integral Sleeve¹

Type A Dynamic Curtain Fire Damper Round Transition

- For use in dynamic HVAC systems (fans on)
- Blade stack in the airstream
- Approximately 75-85% Free Area
- Sleeve optional (Factory welded or Integral)
- 1-1/2 or 3 Hour Fire Rated

FDD-AR Minimum & Maximum Sizes:

Round A Model	Minimum Size		Max. Single Section		Max. Multi-Section ²	
	1.5 Hour	3 Hour	1.5 Hour	3 Hour	1.5 Hour	3 Hour
FDD-VAR (Vertical)	4" Dia. (102)		34" Dia. (864)	34" Dia. (864)	34" Dia. (864)	34" Dia. (864)
FDD-HAR (Horizontal)			22" Dia. (559)	22" Dia. (559)	34" Dia. (864)	34" Dia. (864)

All dimensions shown in inches, parentheses () indicate millimeters.

X Dimension = Height of Blade Stack

H Dimension = Overall Damper Height (D+2")

D Dimension = Diameter

Notes:

1. Integral sleeves are only offered in 20 gauge and in 12" (305), 14" (356) and 16" (406) lengths.
2. Multi-section dampers will have frame in the airstream, and blades for vertical models more than one damper high.

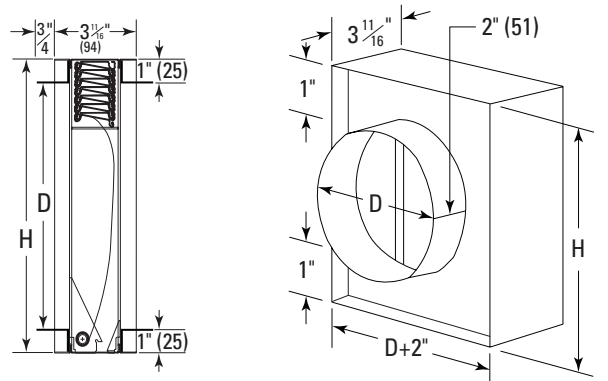

Type AR without Sleeve

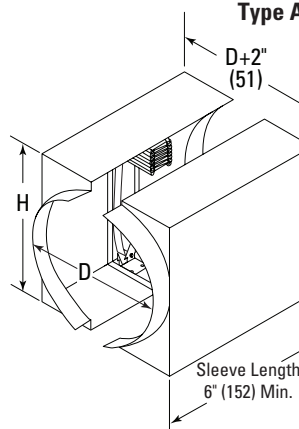

Type AR with Welded Sleeve

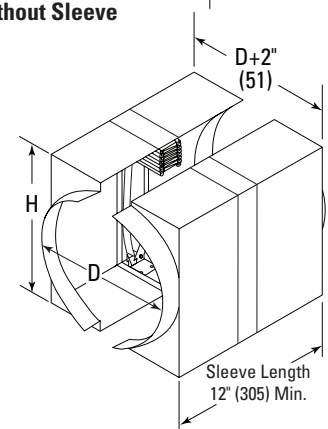

Type AR with Integral Sleeve¹



DIMENSIONAL INFORMATION - Model FDD Dynamic Curtain Fire Damper (for Type B & C)

Type B Fire Damper

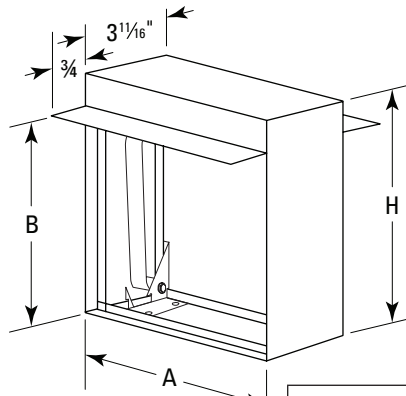

Duct Height (B)	Type B Damper Height	
	Inches	
	Vertical	Horiz.
4	6	6
5	7	7
6	8	8
7	9	9
8	10	10
9	11	11
10	12	12
11	13	13
12	14	14
13	15	15
14	16	16
15	17	17
16	18	18
17	19	19
18	20	20
19	21	21
20	22	22
21	24	24
22	25	26
23	26	27
24	27	28
25	28	29
26	29	30
27	30	31
28	31	32
29	32	33
30	33	34
31	34	35
32	35	36
33	37	-

	Vertical Only
34	38
35	39
36	40
37	41
38	42
39	43
40	44
41	45
42	46
43	48
44	49
45	50
46	51
47	52
48	53
49	54
50	55
51	56
52	57
53	58
54	59
55	60
56	59
57	60
58	61
59	62
60	63
61	64
62	65
63	66
64	67
65	69
66	70
67	71
68	72

Type C Fire Damper

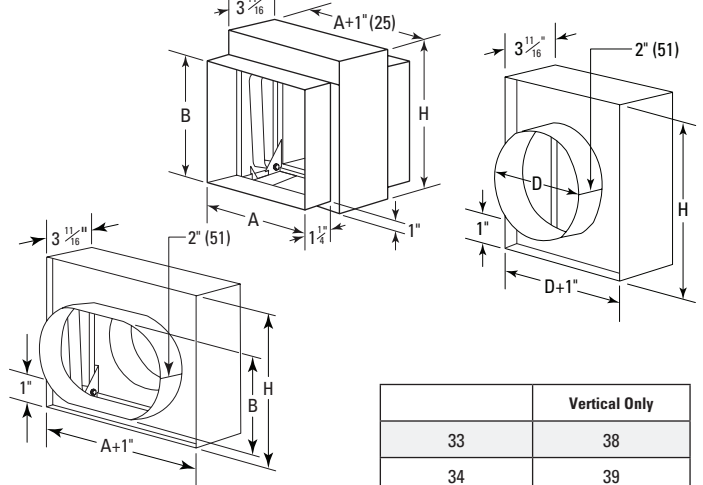

Duct Height (B) or Duct Dia. (D)	Type RC, C, C-O Damper Height (H)
Inches	Inches
3	6
4	7
5	8
6	9
7	10
8	11
9	12
10	13
11	14
12	15
13	16
14	17
15	18
16	19
17	20
18	21
19	22
20	23
21	25
22	26
23	27
24	28
25	29
26	30
27	31
28	32
29	33
30	34
31	35
32	36

	Vertical Only
33	38
34	39
35	40
36	41
37	42
38	43
39	44
40	45
41	46
42	47
43	49
44	50
45	51
46	52
47	53
48	54
49	55
50	56
51	57
52	58
53	59
54	60
55	59
56	60
57	61
58	62
59	63
60	64
61	65
62	66
63	67
64	68
65	70
66	71
67	72

As part of our continuous improvement program, we reserve the right to make further improvements without notice.

Submission - Model FDD - 0120

Multiple section damper assemblies are shipped in individual sections from the factory unless a factory supplied and installed sleeve is required. When a multiple section damper is ordered with a sleeve, it is usually shipped as a complete assembly. The following drawings are of different maximum size multiple section FDD models and are for reference purposes (not all options are shown).

Type A Multi-Section Assembly

FDD-VA Model Shown (max size):
1-1/2 Hour Vertical

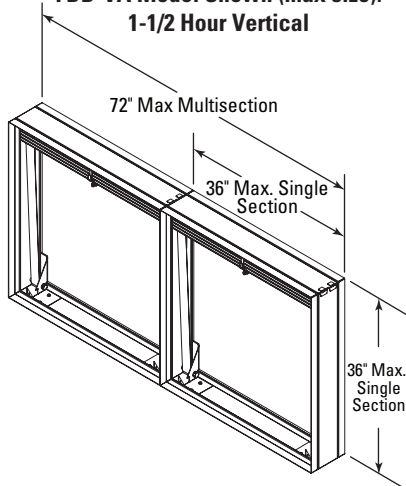

Type B Multi-Section Assembly

FDD-VB Model Shown (max size):
1-1/2 and 3 Hour Vertical

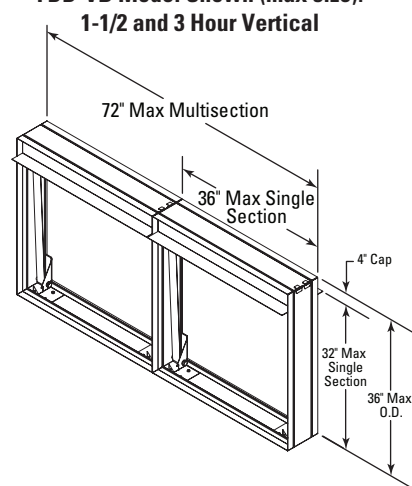

Type C Multi-Section Assembly

FDD-HC Model Shown (max size):
1-1/2 Hour Horizontal

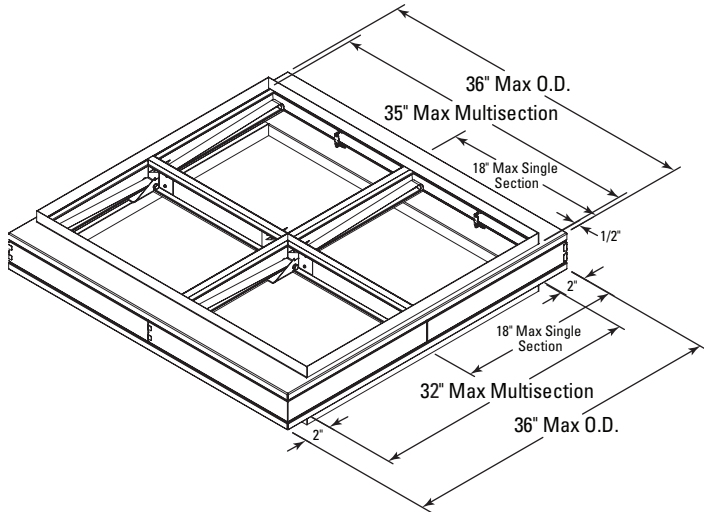

Type C Multi-Section Assembly

FDD-RHC Model Shown (max size):
1-1/2 and 3 Hour Horizontal

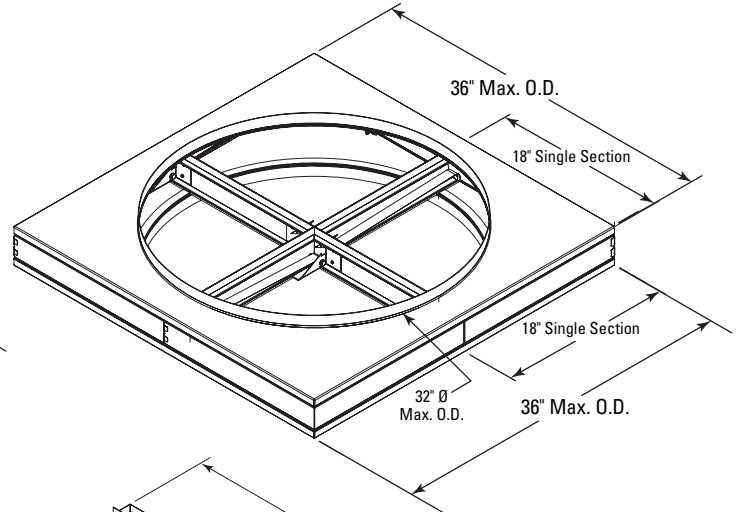

Type B Multi-Section Assembly

FDD-HB Model Shown (max. size):
3 Hour Horizontal

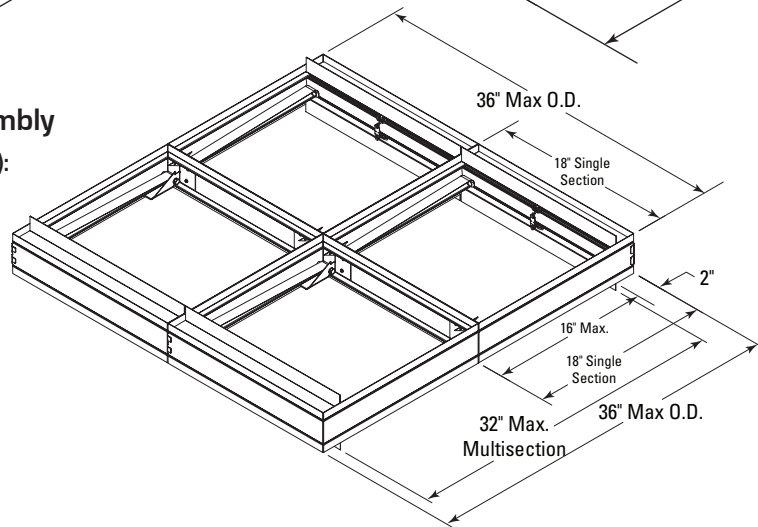

Notes:

1. These diagrams are for reference purposes
2. Not all FDD Model options are shown

As part of our continuous improvement program, we reserve the right to make further improvements without notice.

Submittal - Model FDD - 0120



SLEEVE DIMENSIONAL DATA - Model FDD

Dynamic Curtain Fire Damper

Below are diagrams showing the location of the Type A, B and C fire dampers in welded factory installed sleeve. Integral sleeves (where the sleeve acts as the frame of the damper) are also available.

Sleeve Dimensions:

- H** = Overall damper height
- W** = Overall damper width (always the length of the blades)
- A** = Duct width
- B** = Duct height
- O** = The offset from one end of the sleeve to the middle of the damper frame (can be altered as a construction option)
- L** = Overall length of sleeve

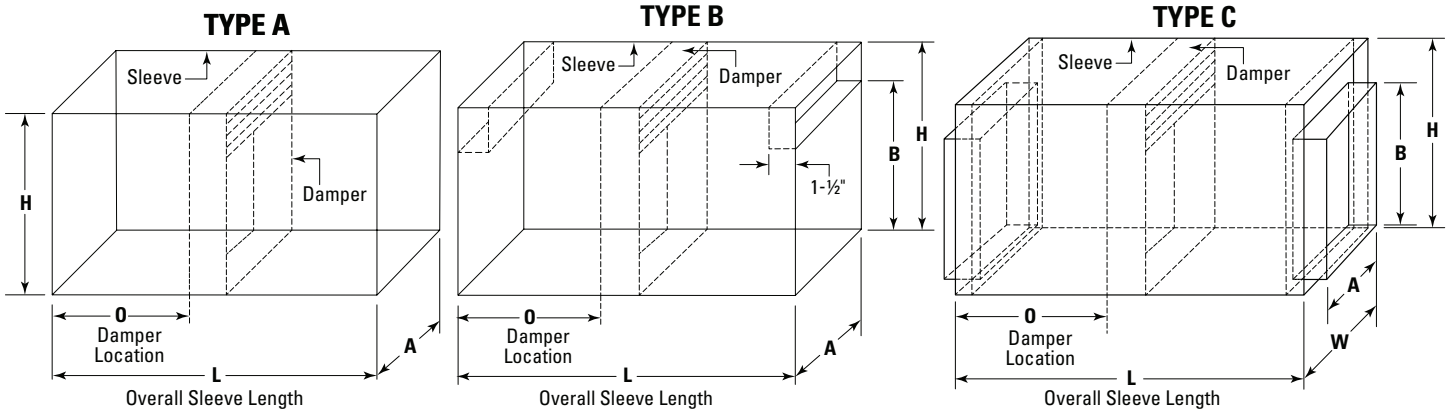

OPTIONAL INTEGRAL SLEEVE INFORMATION

NCA offers the cost and time saving option of having the sleeve be integral to the fire damper. It is offered on any of the fire damper types mentioned in the submittal (A, AR, B, C, R(V/H)C and C-O). On an integral sleeve fire damper, the sleeve acts as both the sleeve and the frame. Integral sleeve fire dampers are available in 20 gauge galvanized steel only and in lengths of 12" (305), 14" (356) or 16" (406). Integral sleeved Fire Dampers are less expensive than factory welded sleeves.

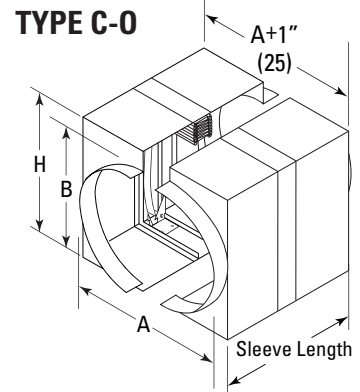
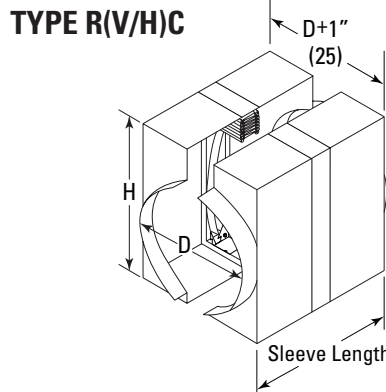
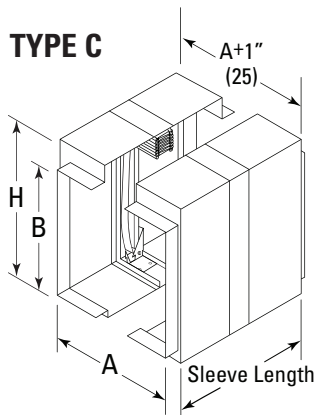
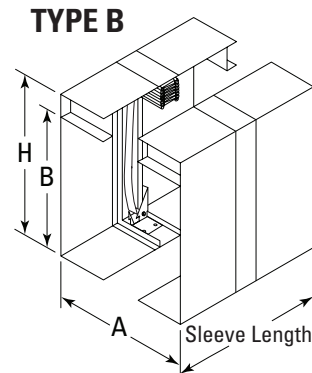
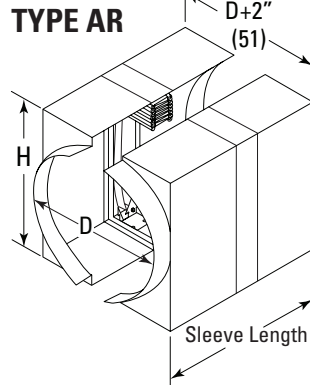
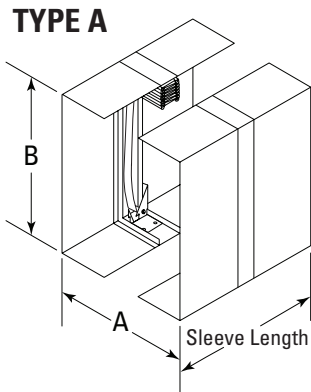

Notes:

Integral sleeve dampers are restricted to single sections.

Refer to the max single section sizes within this submittal for those specific sizes.

As part of our continuous improvement program, we reserve the right to make further improvements without notice.

Submittal - Model FDD - 0120